



safety & security systems

www.safetechsa.com

توريد المواد .

نظام الإنذار المبكر عن الحريق ونظام الحماية .

نظام مكافحة الحريق .

أنظمة الأمن والتحكم بدخول المنشآت و المباني .

أنظمة النداء ونظام الدوائر التلفزيونية المغلقة .

التجهيزات والمواد الكهربائية والإلكترونية.

المولدات الكهربائية.

نظام الكشف عن تسرب الغاز والمياه .

الأشغال الميكانيكية للبناء والمرافق العامة

Material Supply

Fire Detection & Protection System.

Fire Fighting System.

Access Control & Premises Security Systems.

Public Address & CCTV System

Electrical and Electronic Component.

Generators.

Gas and Water Leak Detection System.

Mechanical Works for Building and Public Facilities



Introduction

SAFE TECH EST. Founded in the year of 2010, Safe Tech Est. is a company of fire safety and security system. It recognized as a leading fire protection and emergency systems company, providing a wide range of service with fully qualified and independently licensed team of fire technicians to the kingdom of Saudi Arabia

We did the various projects executed by Safe Tech Est. In both the private and government sectors throughout the Nation. These projects include residential buildings, commercial construction for example (schools, institute, hospitals, malls, sports stadiums, etc.), industrial manufacturing plants, power generation stations, and oil and gas facilities. As we are providing a total fire protection systems. Safe Tech Est. undertakes turnkey projects from design, supply, installation, testing and commissioning of various systems like fire detection, fire alarm, fire suppression, and fire fighting systems which our customers find it very convenient to have all their system requirements provided by Safe Tech Est.

The mission of Safe Tech Est. is to authorize customer to secure business, property and there life's by providing high excellence of quality and advanced fire protection system and using the knowledge of world rank manufacturing processes through best engineering procedure and expand it to kingdom of Saudi Arabia

We will focus on our aim into market sectors that we serve best in "fire safety and security system" and in doing so bring added values to our customers by providing them an "superior Quality and Timely Service at a reasonable Price".

تأسست **مؤسسة التكنولوجيا الآمنة** في عام 2010 وهي مؤسسة تعمل في مجال الأمن والسلامة من الحريق حيث توفر مجموعة واسعة من الخدمات بواسطة فريق مؤهل و معتمد من الجهات المختصة من مهندسين وتقنيين وفنيين في جميع أنحاء المملكة العربية السعودية.

لقد نفذت مؤسسة التكنولوجيا الآمنة مجموعة من المشاريع في القطاعين الحكومي والخاص على حد سواء في جميع أنحاء المملكة العربية السعودية. حيث تم تنفيذ هذه المشاريع في المباني السكنية والتجارية كالمدارس والمعاهد والمستشفيات ومراكز التسوق و الملاعب الرياضية... الخ كما امتدت مشاريعنا للمنشآت الصناعية كمحطات توليد الطاقة الكهربائية ومنشآت النفط والغاز والمصانع. كما نقوم بتوفير مجموعة الحماية من الحريق لمشاريعنا المنفذة بأقصى معايير الجودة من خلال أفضل الإجراءات الهندسية والتقنية وذلك ابتداء من اختيار المواد مروراً بالتصميم والتثبيت والمعايرة وانتهاءً بالإختبار والتدقيق لمختلف أنواع النظم مثل نظام الكشف والحماية من الحريق ونظام إنذار الحريق ونظام مكافحة الحريق . وما يجدر ذكره أن جميع عملاءنا مسرورين للتعامل معنا وذلك مما توفره مؤسسة التكنولوجيا الآمنة من متطلبات ومعايير عالية في جميع الأنظمة.

مهمتنا تأمين منشآت عملاءنا وحياتهم من خلال توفير تميز عال في الجودة ونظم متطورة للوقاية من الحريق واستخدام المعرفة في عمليات التصنيع والتثبيت من خلال أفضل الإجراءات الهندسية ليمتد ويشمل جميع مناطق المملكة العربية السعودية.

هدفنا خدمة عملاءنا في جميع قطاعات سوق العمل وتقديم الجودة العالية لأنظمة الأمن والسلامة من جميع أنحاء العالم وصقلها بالعمل الهندسي المتميز في وقت مناسب وبقيمة تنافسية.

Index

	Commercial CCTV Security Cameras
	Fire Alarm System
	Fire Alarm System
	Fire Alarm System
	Fire & Building Products
	FM 200 Extinguishing released by automatic
	Batteries
	Cables
	Nickal Cadmium Batteries
	Sprinklers
	Fire Pumps
	Gate Valve
	Fire Extinguisher
	Fire Fighting Equipment
	Automatic Gates



CCTV SECURITY CAMERAS



Features

Basic System includes:

- Capacity for up to 1000 addressable devices, up to 127 VESDA SLI points, up to 2000 points of Annunciation and up to 20 internal and external card addresses
- Color-coded operator interface with membrane keypad includes 2 x 40 Super-twist LCD display, 3 programmable control keys and 6 programmable LEDs
- CPU assembly includes dedicated compact flash memory for on-site system information storage and convenient Ethernet service port access
- 8 Amp power supply with up to 2 Amps of Auxiliary power and battery charger capacity for up to 110 Ah batteries (UL) or up to 50 Ah batteries (ULC) (33 Ah max in single bay control cabinet, 50 Ah max with 4100-0650 battery shelf in two bay control cabinet)
- 4 on-board Class A or B 3 Amp NACs and one programmable auxiliary relay output rated for 2 Amps @ 32 VDC
- Class A or B Two-loop Isolated IDNet™ Communications (IDNet+) supports up to 248 addressable and analog sensing devices on non-twisted, non-shielded wiring
- Remote annunciator module support via RUI (remote unit interface) communications port, either Class B (Style 4) or Class X (Style 7) Pathway operation
- 48 LED panel mount annunciation provides 40 Red and 8 Yellow pluggable LEDs (select models), optional LED kits are available for custom LED configurations
- Available with InfoAlarm™ Command Center expanded content user interface (two bay cabinet required)

Optional MSS and Door Mount Modules include:

- City Connect (with or without disconnect switches), Alarm Relay Module

Optional Block Space Modules include:

- Fire Alarm Network Interface Card for 4120/4100 Peer-to-Peer network communications, supports either Class B or Class X (Style 7) Pathway operation
- Ethernet connectivity options include Building Network Interface Module (BNIC) and SafeLINC Internet Interface
- Dual RS-232 Module (for printer, PC annunciator or third party interface)
- VESDA® Air Aspiration High Level Interface
- Serial DACT
- 8 Zone IDC Modules Class A or B
- 4 Point Auxiliary Relay Module
- Physical Bridge Network Modules
- Additional IDNet+ and MX Loop addressable device modules



4010ES Fire Alarm Control Panel
with or without LED Annunciation

Compatible with Simplex® remotely located:

- 4003EC Small Voice Panels
- 4009 IDNet NAC Extenders
- 4009 TrueAlert Addressable Controllers and TrueAlert Power Supplies (TPS)
- 4081 110Ah Battery Chargers
- 4100-7400 Series Graphic Annunciators
- 4190 PC Annunciator
- 4190 Fiber Modems and Physical Bridges
- 4606-9102 Remote LCD Annunciator and 4100-9400 Series Remote InfoAlarm Command Centers
- IP communicator compatibility

4010ES Agency Listing:

- UL Std. 864, Fire Detection and Control (UOJZ), and Smoke Control Service (UUKL)
- UL Std. 2017, Process Management Equipment (QVAX)
- UL Std. 1076, Proprietary Alarm Units-Burglar (APOU)
- UL Std. 1730, Smoke Detector Monitor (UULH)
- ULC Std. S527-99



Campus Style Network Multiple Connectivity Options

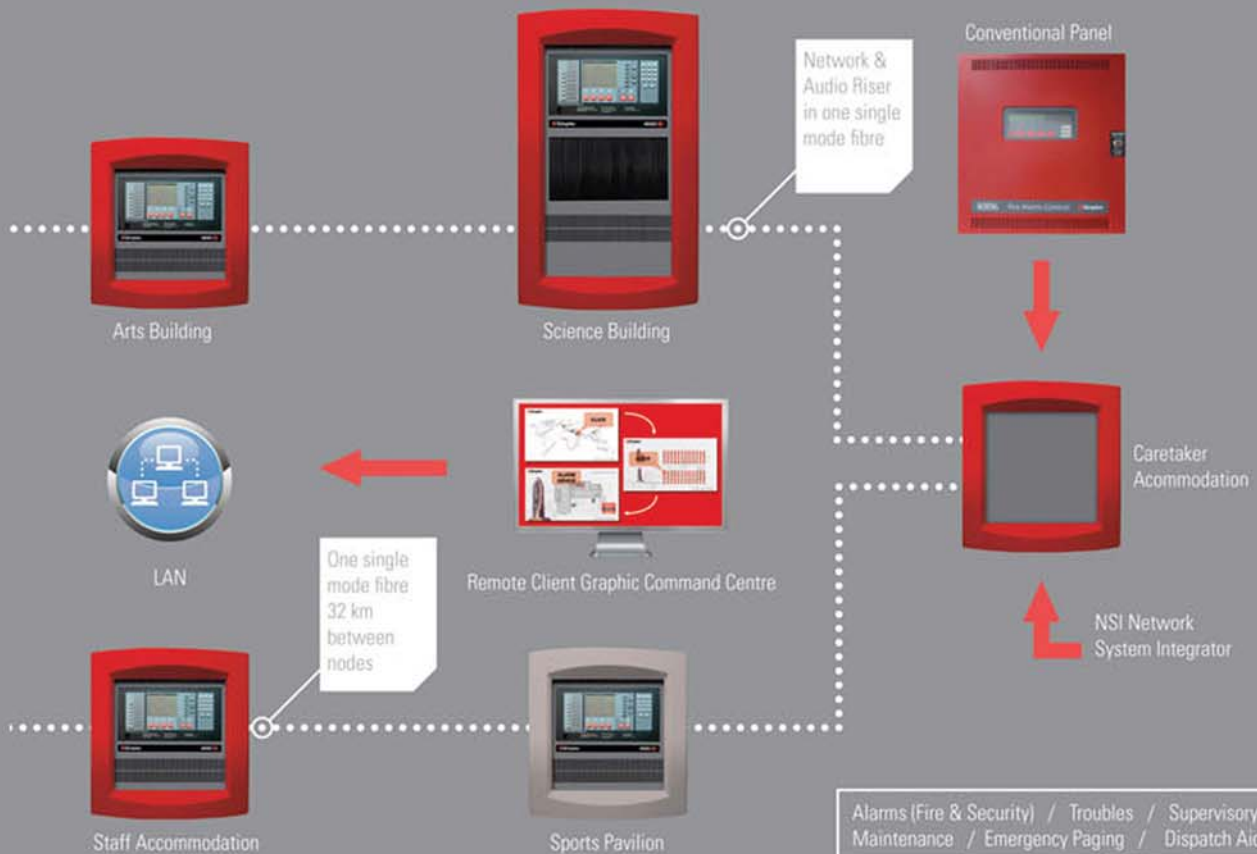
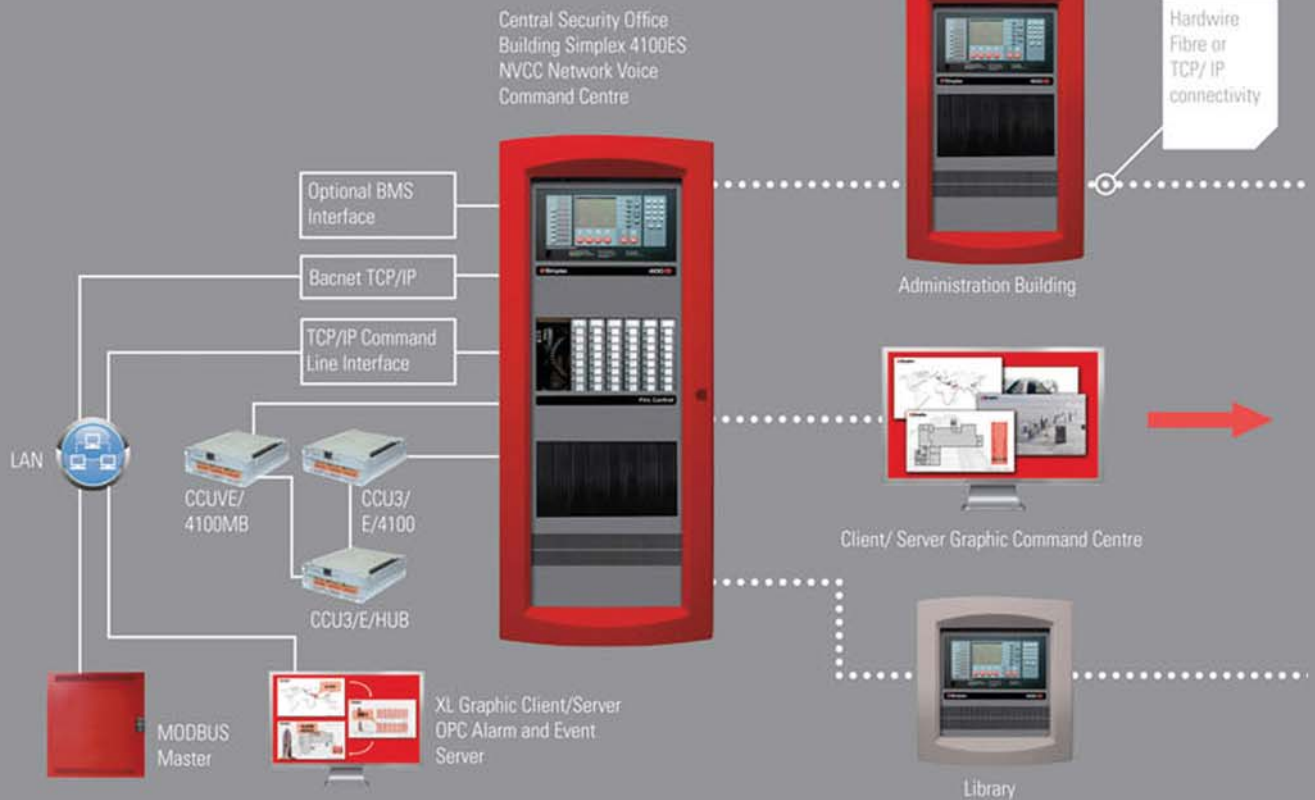

ANALOGUE FIRE DETECTION
VIGILON CONTROL PANEL

A one to four loop panel accommodating up to 200 devices per loop. Up to 31 panels may be connected in a secure network.

LCD display allows clear indication of fire or fault location.

Site specific fire plans can be programmed to meet the evacuation needs of the building.



Vigilon Control Panel

Technical Specification

Type	Control panel
Max No of Loops	4
Loop Capacity	200
Batteries	4 x 12V @ 12AH
Battery Standby	24 hours standby + 30 minutes alarm upgradeable to 72 hours
Approx Weight	16.2 Kg
Ambient Temperature	0°C to 45°C
Relevant Standard	BS 5839: Part 4 + EN54 Part 2 + 4
Cable Entry	Top and rear knockins
Approvals	LPC approval to BS 5839: Part 4

ORDER CODES

EN 54 Control Panels
(For BS 5839 versions add the suffix -V3+ e.g. VIG1-NET-V3+)

- 1 Loop VIG1
- 2 Loop VIG2
- 3 Loop VIG3
- 4 Loop VIG4
- 1 Loop, Networkable VIG1-NET
- 2 Loop, Networkable VIG2-NET
- 3 Loop, Networkable VIG3-NET
- 4 Loop, Networkable VIG4-NET

Note: Control panels require a first fix, VIG-1ST-FIX

	A	B	C
Control Panel	408	539	151
Battery Box	382	309	112

Dimensions (mm)

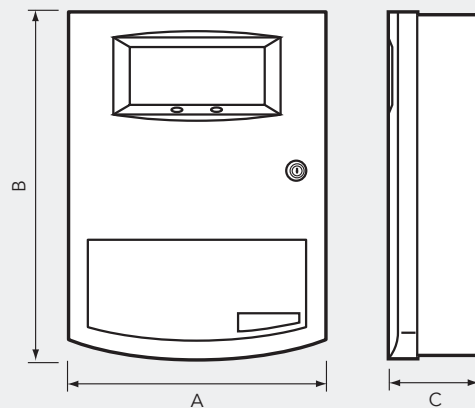

Xenex control panel

The Xenex panel complies fully with the European standard EN 54 Parts 2 & 4 and can be used on installations meeting BS 5839-1.

Each panel contains its own integral power supply and battery support for up to eight alarm sounder circuits, two auxiliary relay contacts, a zone disablement facility and a one man test and commission facility, all simplifying system design, installation and commissioning.



Xenex Control Panel

TECHNICAL SPECIFICATION					
No. of Zones	1	2	4	8	*8 Zone Repeat
Maximum Load per Zone	3mA	3mA	3mA	3mA	N/A
No. of Sounder Circuits	2	2	4	8	N/A
Max. Sounder Circuit Load	0.5A per circuit Total load not to exceed 1A				N/A
Batteries (seperate)	2 x 12V, 2.1 Ah		2 x 12V, 2.8 Ah		2 x 12V, 2.1 Ah
Battery Standby	72 hours plus 0.5 hours alarm load				72 hours
Aux. Relay Contacts	1 N/O and 1 N/C pair, 1A at 24V				N/A
Approx Weight (with batteries)	5.8 Kg	5.8 Kg	5.8 Kg	6.2 Kg	5.8 Kg
Relevant Standard	EN 54 Parts 2 & 4				
Approvals	LPCB approved to EN54: Parts 2 & 4				
Cable Entry	13 Top and 13 Rear				
Cable Type	BS 6387, 2 core, min 1.5mm ² CSA				
Class Change Facility	Via normally open push button switch located no more than 100m from panel				N/A
Operating Temperature	Indoor, 0 - 40°C				

Note: Maximum of 1, 8 zone repeat panel per system.

Note: For maximum system loading table see page 20.

Dimensions of all panels (inc Repeat panel) (mm)

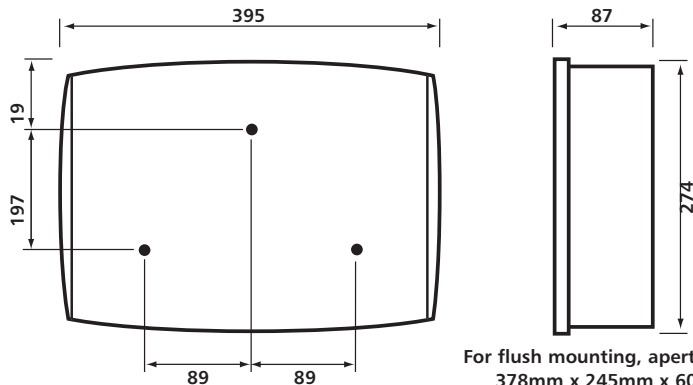

ORDER CODES

1 Zone	13270-01LB
2 Zone	13270-02LB
4 Zone	13270-04LB
8 Zone	13270-08LB
8 Zone Repeat	
Panel	13271-08LB
Flush Surround	13270-29LB

(Batteries to be ordered seperatly)

CONVENTIONAL FIRE DETECTION

GENT
by Honeywell

Xenex system architecture

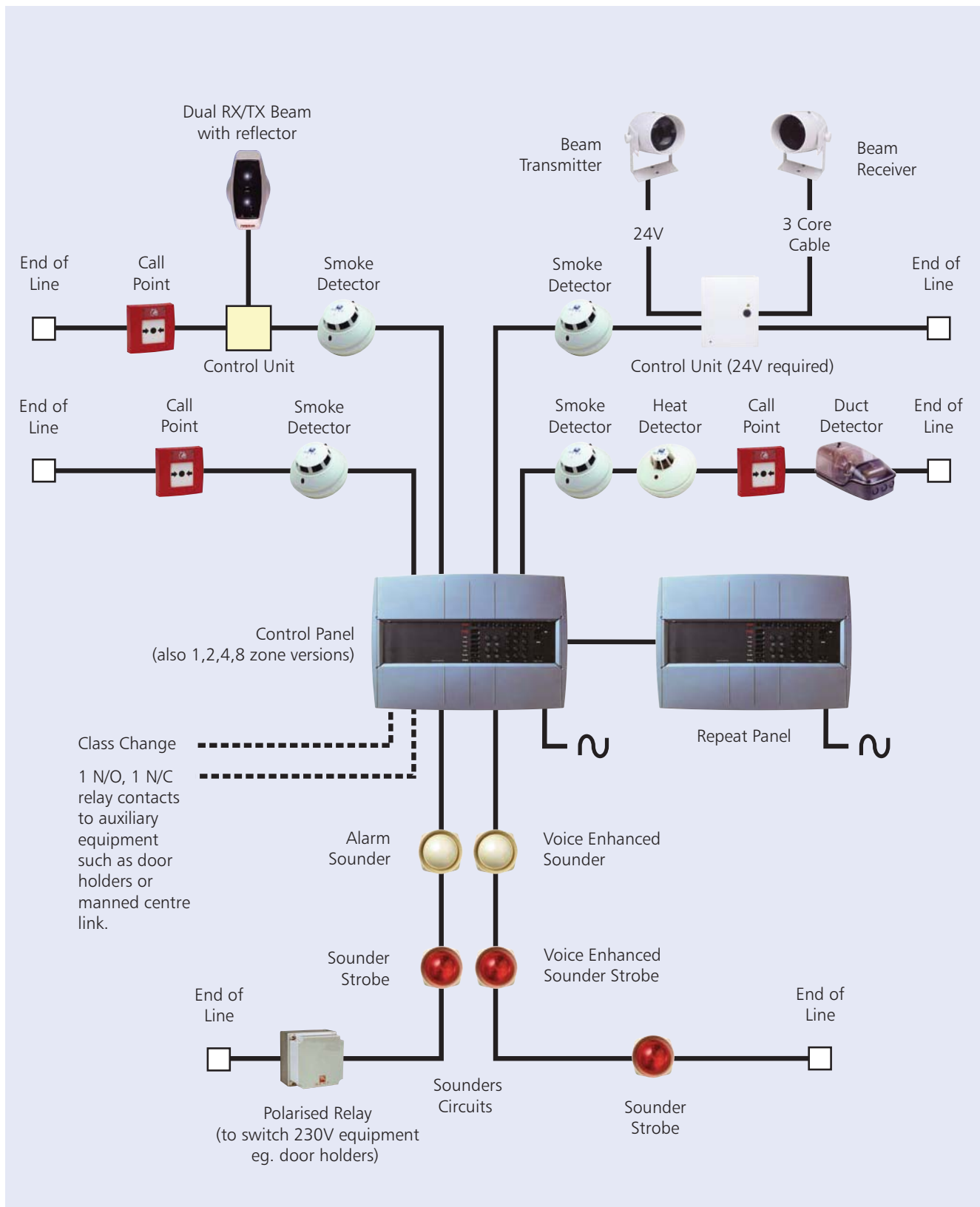

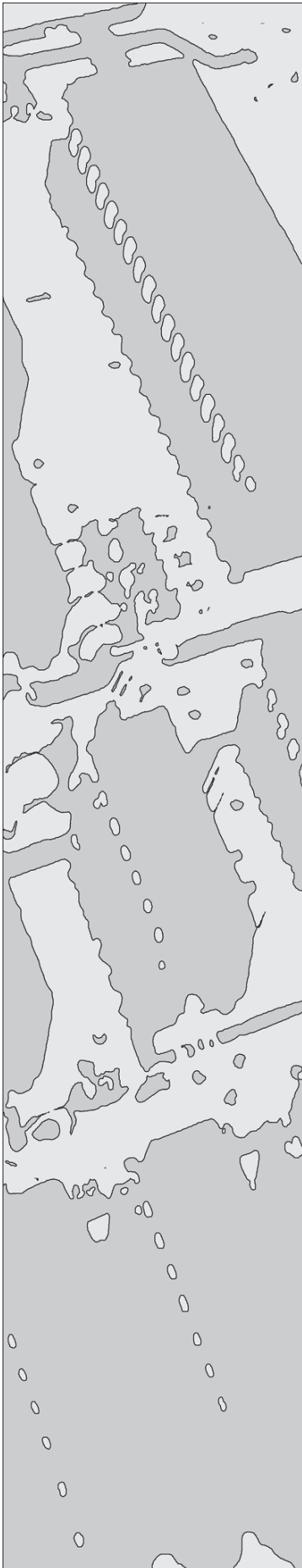

Sigma XT Extinguishant Control Panel



MODEL NUMBERS
K11031M2, K11031F2

Tyco MX Technology

Tyco MX Technology brings together the latest fire detection technology from around the world into a comprehensive international range of fire detection systems. *Tyco MX Technology* can be used to provide cost effective solutions on small fire detection systems whilst also providing the features and functions required on very large commercial and industrial sites.

Features

- *MX VIRTUAL* multi-sensor detectors
- *MX DIGITAL* robust & reliable high speed loop protocol
- Rapid response to fire conditions and very low false alarms through:
 - *MX FASTLOGIC* detection algorithms
 - *MX HPO* detection algorithms
 - *MX CCO* fire detection



MX Technology

Tyco MX Technology is being made available on a wide range of internationally approved panels and systems available from Tyco companies world-wide including:

- *MINERVA MX PANELS*
- *MINERVA MARINE T2000 PANELS*
- *ZETTLER EXPERT PANELS*
- *MINERVA SOLO PANELS*



MX Detection Panels

Tyco MX detection panels use all the features of Tyco MX Technology to provide the latest fire detection technology meeting the latest worldwide standards in cost-effective, expandable packages.



Tyco MX detection pan

- MX VIRTUAL Multi-sensor detectors
- MX DIGITAL high speed reliable digital protocol
- MX FASTLOGIC fuzzy logic smoke detection algorithms
- MX CCO universal carbon monoxide fire detection algorithms

Tyco MX detection panels provide modular cost effective solutions:

- Networked panels from 1 to 792 detection loops
- Powerful central loop processing functions
- Powerful and modular user interface
- MX REMOTE diagnostics and service functions
- MX GRAPH graphical user interfaces
- Designer and modular housing options

Tyco MX detection panels provide long term fire detection solutions including upgrade paths from earlier panel models and a long term development strategy providing future upgrade paths.

Tyco MX detection panels include:

- MINERVA MX for EN54 LPCB approved systems
- ZETTLER EXPERT for EN54 LPCB & VdS approved systems
- MINERVA EXPERT T2000 for Marine approved systems

Tyco MX detection panels include a powerful user interface:

- 640 Character display
- Displays first alarm and most recent alarm
- Permanently displays systems status including number of alarms, number of faults, number of isolated points
- Scroll function allows details of all events and status to be easily viewed
- Displays temperature, CO level and smoke level at point in alarm

procedures

for emergency

Tyco MX panels include advanced manager and engineer functions including:

- Menu driven
- Multi-level password protected
- Viewing 3000 event log
- Detailed fault reporting
- Isolate by point, zone or sector
- Viewing and printing status
- Viewing and printing isolated points
- Manual and automatic walk test and reporting functions
- Viewing and printing maintenance reports
- Extensive diagnostic functions including simulation and force outputs
- Text and configuration changes/Automatic battery test
- Detector service functions

Tyco MX detection panels include very powerful event/action programming including:

- Seamless network wide event/action
- 240 x 240 Output map and output sequencing algorithms
- Over 1500 event/action groups for the most complex applications
- Templates for fast programming of standard applications including:
 - EN54/BS5839
 - EN54/VdS
 - EN54 Marine
- User defined templates
- Time, date and special day programming
- Wide range of co-occurrence, double knock and delay functions

Conventional Fire Alarm Panels - BS5839 and EN54

MINERVA MXC panels are the first products in a whole new family of fire detection and extinguishing controllers for the high volume, small systems end of the world-wide fire detection market.

The product design provides a highly featured, low cost product with features incorporated to reduce installation costs, simplify connection to central alarm monitoring stations and allow service upgrades of old installations.



MINERVA MX Conventional Panels

MINERVA MXC is a range of low cost 2,4, and 8 zone EN54 detection panels incorporating the following key features and functions.

Power Supply

The power supply is designed to comply with the latest standards (EN54pt4) as well as providing full battery back-up capabilities. A re-settable power output enables beam detectors and other devices to be powered and be reset from the panel.

- Up to 72 hours standby plus 30 minutes alarm
- 2A PSU/charger with 1.5A available for detectors, sounders (2x500mA) and auxiliary devices (24V 250mA)
- Space for 2 x 7Ah batteries internally

Panel Functions

For normal operation the MXC requires no configuration. Other typical options can be easily selected on links inside the controller. An optional advanced programming mode changes the function of the standard user interface to allow powerful bell mapping and delay options, which are only normally found on much higher priced panels.

- One Man Weekly test option
- One Man Zone and Sounder walk test
- Zone Disable (Isolate) functions
- Cross zoning/coincidence on Zones 1 & 2
- Bell Mapping
- Optional Sounder delays
- Optional reset on auxiliary 24V

Inputs and Outputs

The Detection circuits support 2-Stage alarm, Alert and Evacuate, which can be used for different sounder responses. Whilst auxiliary inputs allow school class change to be configured to existing installations, signalling faults to be monitored and non-latching alarms from landlord systems to be implemented.

- Detection circuits monitored for detector removal
- Tyco 2-Wire sounders can be installed on the detection zones 1 to 4
- Two stage alarms "Alert" and "Evacuate"
- Class change input (output follow input)
- Non-latching alarm input

Features

- Approved to EN54 pt 2 & 4
- Operates with Tyco Series 600 LPCB Vds approved detector ranges
- 2,4 and 8 zone variants
- Tyco 2-Wire sounders on the first 4 detection zones
- Supports a plug-in Central Station communicator
- Programmable mapping of detection circuits to sounder circuits.

Installation features

- Customised zone text insert
- Surface or semi-flush mount
- Reversible back-box for top or bottom conduit and cable entry
- Terminations that suit up to 2.5mm² CSA cable

- Non-latching fault input
- Auxiliary input for signalling fault monitoring
- Signalling fire and fault outputs (with optional monitoring/supervision of the connection)

Input/Output Expansion

An optional plug in board provides a host of inputs and outputs for the most complex applications. Eight zone panels are fitted with this board and the connections for 4 of the detection zones are made on this board, however, this board will not expand a two or four zone unit into an eight zone.

- Additional fire and fault relays.
- Up to 8 x Zonal Outputs
- Optional remote evacuation/silence and reset inputs for system integration

FIRE BRIGADE (CS) SIGNALLING AND REMOTE ENGINEERING

Two signalling options are available for UK Central Stations.

MXC-DIGI

A plug-in digital dialler which fits inside the panel and provides fire, fire test and fault signalling.

REDCARE STU

This standard ADT RedCARE STU is also compatible with the MXC panels.

Note: REDCARE is the only LPCB approved signalling solution for the UK.

MINERVA MXC DEVICES

Branding

MINERVA MXC detection panels are supplied with multiple tyco business branding for affixing during commissioning (Tyco, ADT, Wormald, Zettler and Thorn branding). Detectors and call-points are also available in these brands.

Approvals

The MXC range complies with EN54 pt 4.

NTR - Typical Wiring Schematic for Single Area Panels

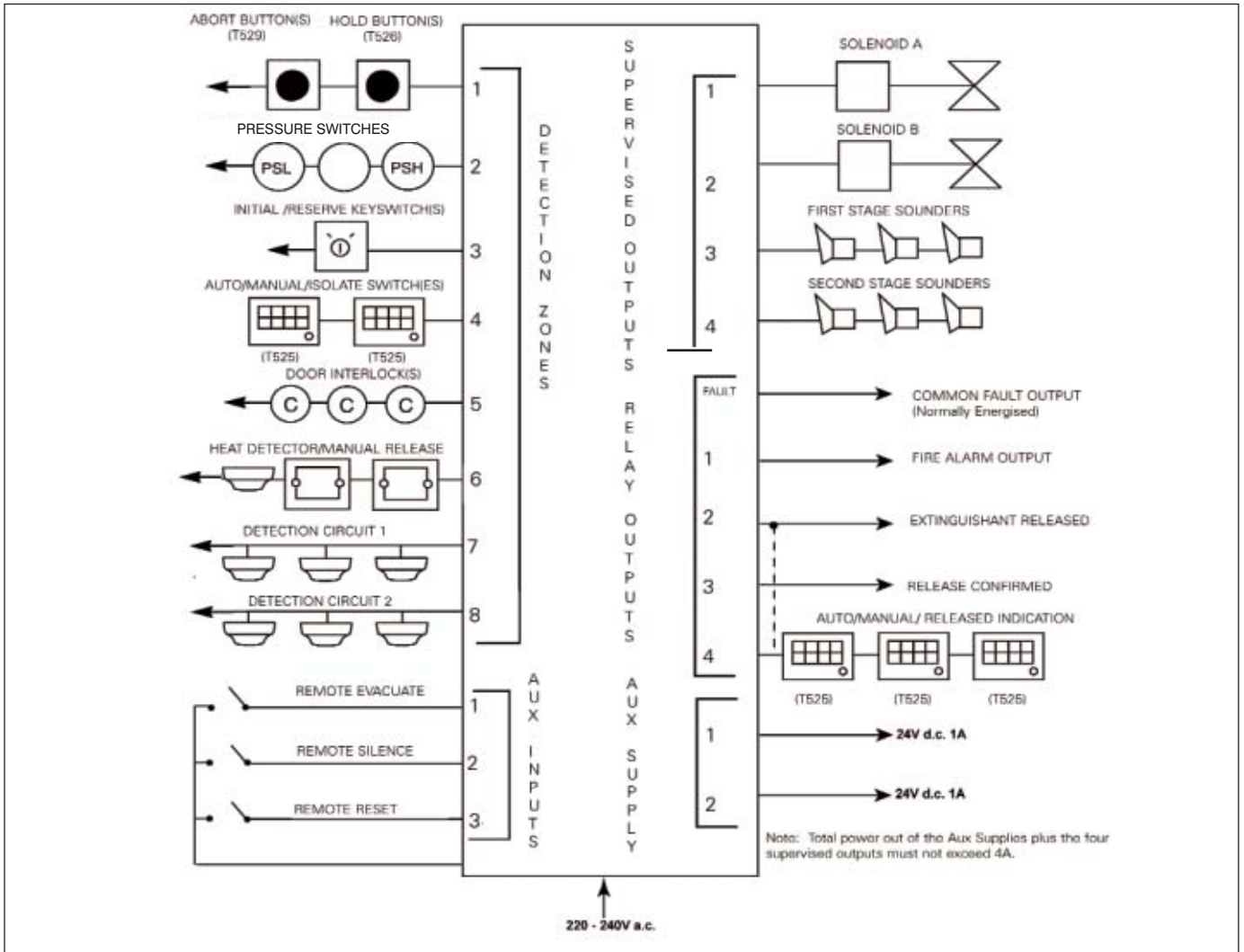

Typical Extinguishing Gas Release Applications

Extinguishant Schematic Configuration with Extinguishant Solenoid

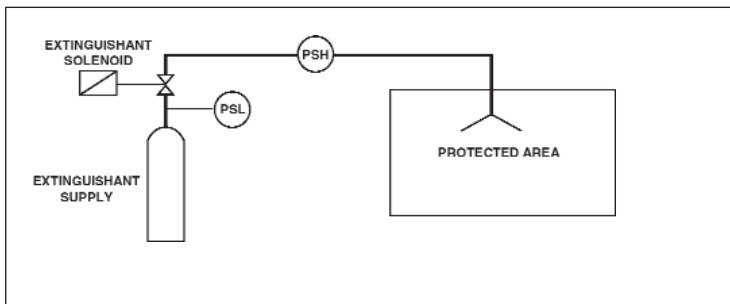

Extinguishant Schematic Configuration with Pilot Container Solenoid

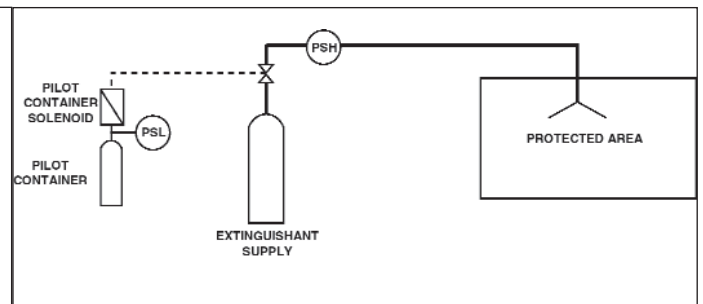

Extinguishant Initial/Reserve Schematic with Extinguishant Solenoid

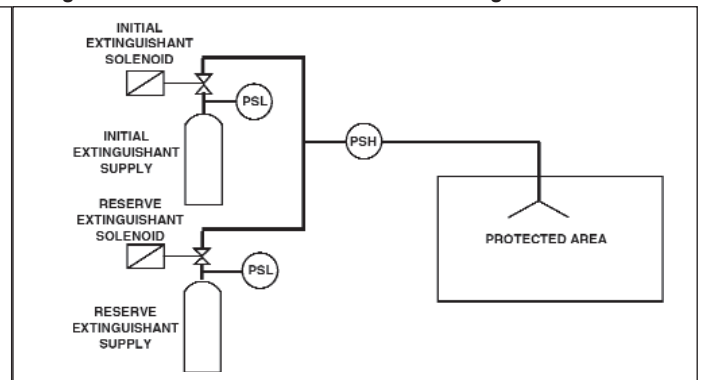
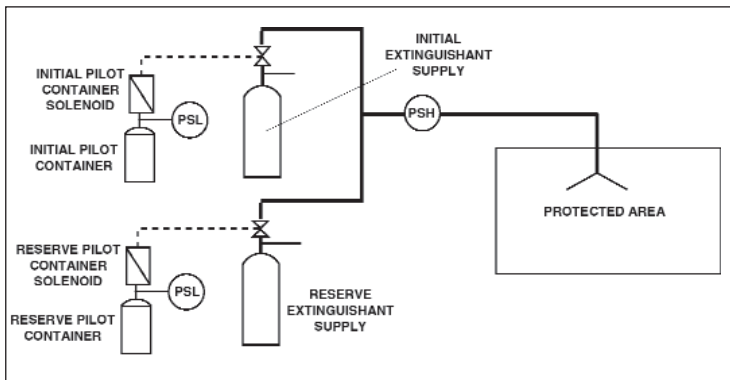

Restaurant Fire Suppression Systems

SEQUENCE OF OPERATION OF R 102 SYSTEM

The system consists of a regulated mechanism fitted with a nitrogen cartridge, pre-engineered nozzles, detectors with fusible links and optional accessories like electrical switches, manual pull stations, manual reset relays.

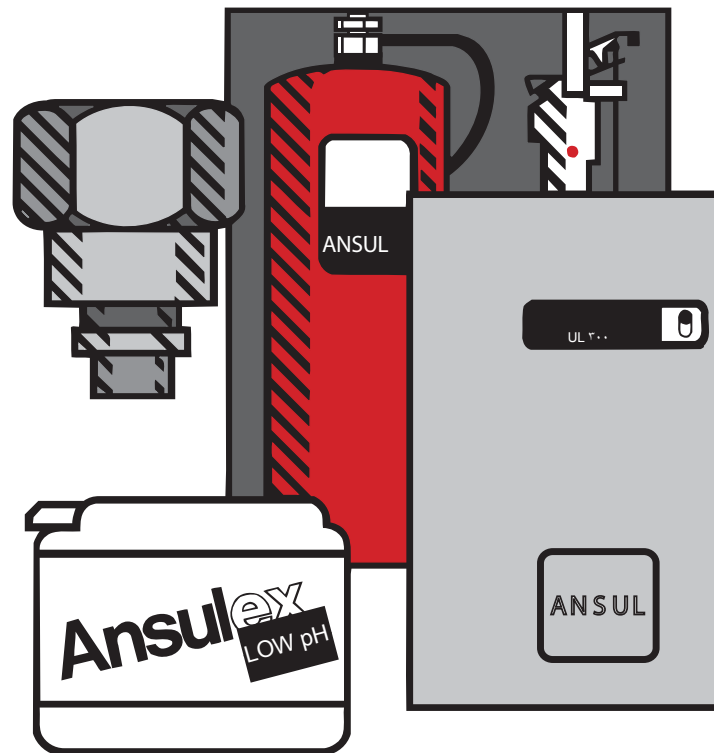

The system operation can be summarized as follows:

1. when the temperature exceeds the pre fixed temperature of fusible link of the detector, the link fuses thus loosening the tensed wire rope fitted the release mechanism.
2. when the tensed wire rope releases, the cocked mechanism gets actuated thus releasing the compressed gas of the cartridge.
3. the then released gas compresses the liquid agent to form like a foam and push by the pressure to pass through the preengineered pipe network and nozzles.
4. when the system starts extinguishing, the electrical switch associated with the mechanism changes the state of contact thus giving a signal which can be utilized for shutting off a solenoid gas shut off valve and fresh air fans.
5. the manual reset relay is utilized to reset the function of the solenoid valve.

Belden



INDUSTRIAL
RESIDENTIAL
BROADCAST
NETWORKING
SOUND, SECURITY & ALARM

ELECTRONIC WIRE & CABLE
FIBER OPTIC CABLE



NP Baureihe – Series

Ventilgesteuerte Bleiakumulatoren
Valve Regulated Lead-Acid Batteries



YUASA BATTERY (EUROPE) GmbH

YUASA



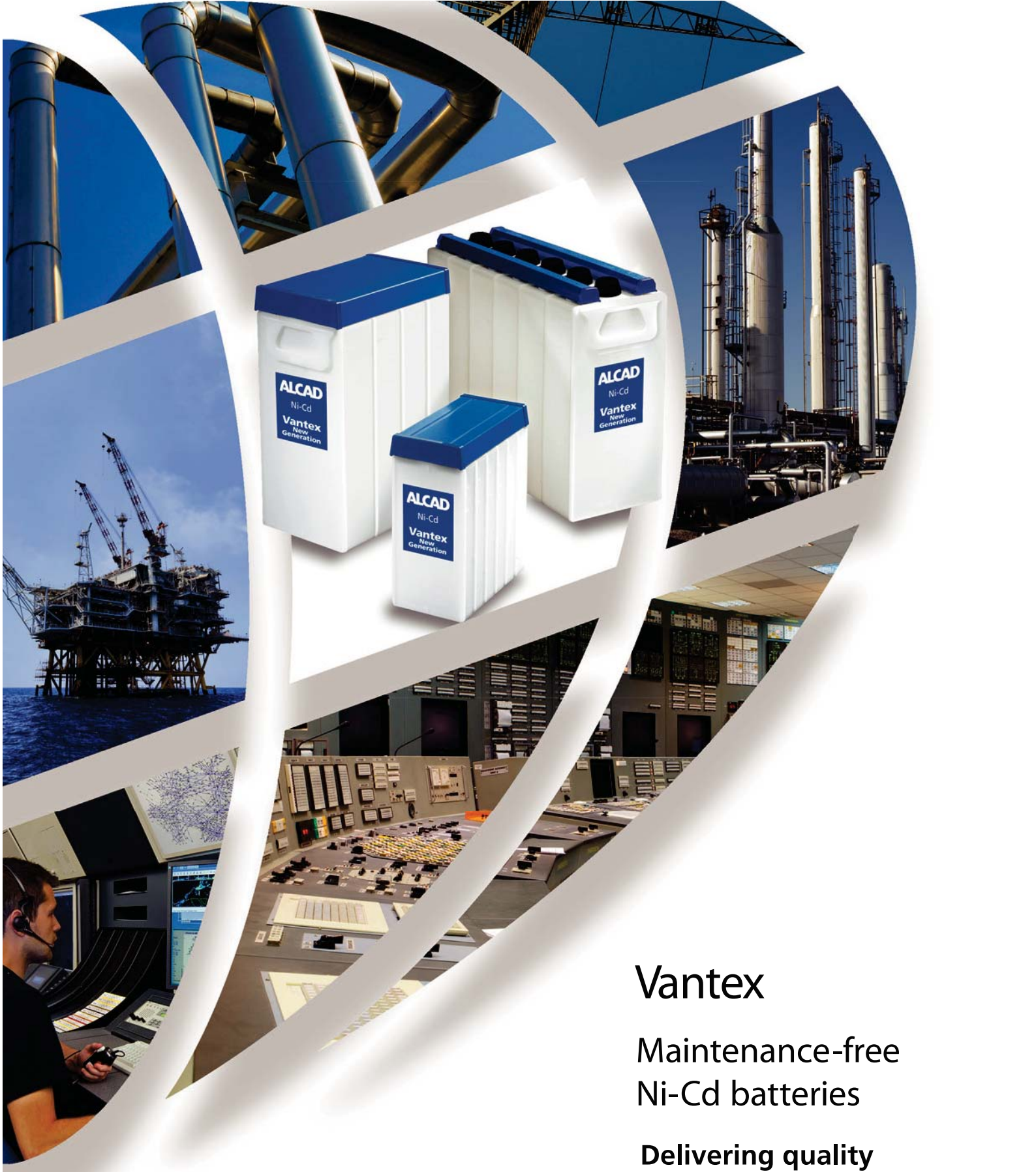

Vantex

Maintenance-free
Ni-Cd batteries

Delivering quality

ALCAD

**QUICK RESPONSE
AUTOMATIC SPRINKLERS
GL SERIES**

**UPRIGHT • PENDENT
VERTICAL SIDEWALL
HORIZONTAL SIDEWALL
CONVENTIONAL (OLD STYLE)**



DESCRIPTION AND OPERATION

The Globe Quick Response GL Series Sprinklers are a low profile yet durable design which utilizes a 3mm frangible glass ampule as the thermosensitive element. This provides sprinkler operation approximately six times faster than ordinary sprinklers. While the Quick Response Sprinkler provides an aesthetically pleasing appearance, it can be installed wherever standard spray sprinklers are specified when allowed by the applicable standards. It offers the additional feature of greatly increased safety to life and is available in various styles, orifices, temperature ratings and finishes to meet many varying design requirements. Quick Response Sprinklers should be used advisedly and under the direction of approving authorities having jurisdiction.

The heart of Globe's GL Series sprinkler proven actuating assembly is a hermetically sealed frangible glass ampule that contains a precisely measured amount of fluid. When heat is absorbed, the liquid within the bulb expands increasing the internal pressure. At the prescribed temperature the internal pressure within the ampule exceeds the strength of the glass causing the glass to shatter. This results in water discharge which is distributed in an approved pattern depending upon the deflector style used.

TECHNICAL DATA

- See reverse side for Approvals and Specifications.
- Temperature Ratings - 135°F (57°C), 155°F (68°C), 175°F (79°C), 200°F (93°C), 286°F (141°C)
- Water Working Pressure Rating - 175 psi (12 Bars)
- Factory tested hydrostatically to 500 psi (34 Bars)
- Maximum low temperature glass bulb rating is -67°F (-55°C)
- Frame - bronze • Deflector - brass • Screw - brass
- Bulb seat - copper • Spring - nickel alloy • Seal - teflon

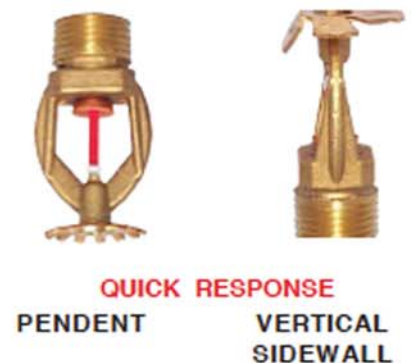





KENNEDY VALVE



KENNEDY VALVE a DIVISION OF MCWANE



Stored Pressure Powder Extinguisher

HEBA Provides a wide range of highly effective stored pressure **ABC DRY CHEMICAL POWDER EXTINGUISHERS**, suitable for most FIRE CLASSES.

The extinguisher body is constructed from COLD Rolled Steel (CRS), which is then fabricated by Automatic Metal Inert Gas (MIG) welding process. Afterward, The body is thoroughly Shot Blasted and pretreated with zinc phosphate to improve corrosion resistance and paint adhesion, as well as gloss finish, each extinguisher is Electro-statically Painted, using a POLYESTER RESIN, before being baked in the oven.

Each extinguisher is pressurized by a suitable propellant gas mixed with an inert gas (helium) then subjected to a helium testing machine to check if any leakage exists.

The small powder residues remaining total discharge ensure Optimum Fire Fighting Capacity. The Dry Chemical Powder is capable to deal with class A fires involving carbonaceous materials like wood, paper etc. also deal with class B fires involving flammable gasses and flammable liquids. Also can be applied for Electrical Fires.



Other Features of this Range of Extinguishers are:

- Highly visible pressure indicator.
- Supplied with hose and horn.
- Durable textile fibers re-in forced fire hose
- Highly resistant fire hose to abrasion of extinguishing agent.
- Supplied complete with wall mounted bracket.
- Controllable discharge which allows optimal use of the fire extinguishing agent.
- Suitable for Type A, B and C fire classes.
- Easy to use, simple to maintain, and refillable.
- Supplied complete with safety valve.

PORTABLE
POWDER



Fire Hose Cabinets



Fire Hose Cabinets - VH 600S

Manufactured in accordance with highest technical and international standards. Such products can be used different industrial & power plants, residential, commercial buildings, hospitals and schools that require protection from class A & B fires.

Fire Hose Cabinets - VH 600

Manufactured in accordance with highest technical standards and international qualification. Such products can be used in industrial & power plants, residential, commercial, hospital building and other installation that require protection from class A & B fires.



Foam Cabinets - VH 9000

Volcano foam - water cabinets Model VH-9000 are characterized by its performance for attacking class A & B Fires. , Effectively used gas stations, petrochemical plants, industrial premises, warehouses, car parking, paint factories and any situations requiring foam protection.



CAME
AUTOMATIC GATES

CAME Products Series

CAME Barrier System



G2500, G40000
& G5600

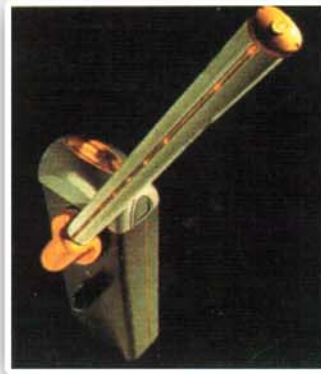

G8000



G12000

CAME Sliding Gate System

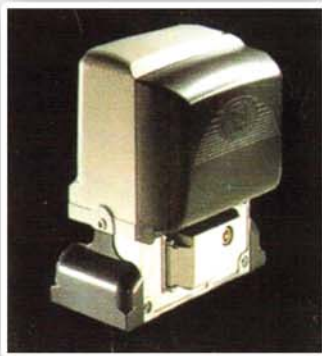

BX 400 - 800 Kg

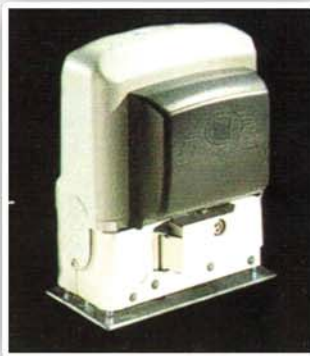

BK 1200 - 2200 Kg



BK 3500 Kg

CAME Swing Gate System



ATI 3000 - 5024

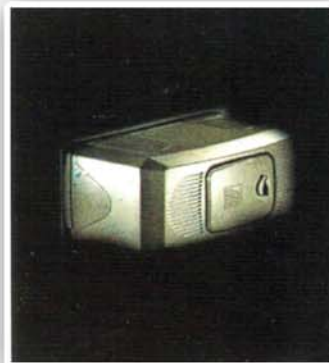

Ferni F1000 - F1100



Frog-A , Frog-AV
& Frog-A24

References



الهيئة العامة للغذاء والدواء
Saudi Food & Drug Authority



Civil Architecture - Electro mechanical
مدني العمارة - ميكانيكي الكهربائية





safety & security systems

safetechsa@hotmail.com

www.safetechsa.com

Tel. : +966 114726422
Fax : +966 11 4724922
P.O.Box : 12642
Riyadh - 3482
Kingdom of Saudi Arabia